

# Sliding Roof

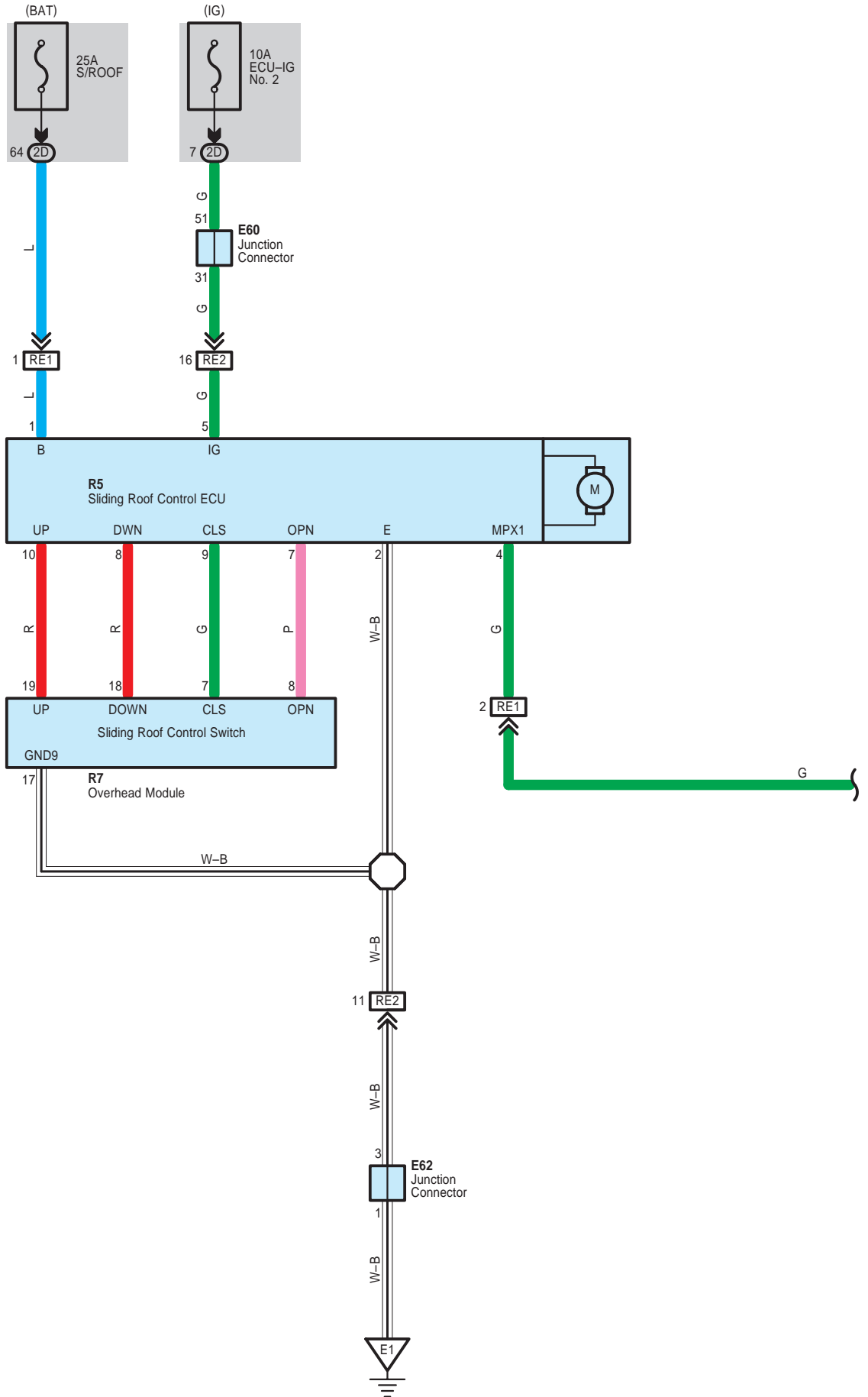

# Sliding Roof

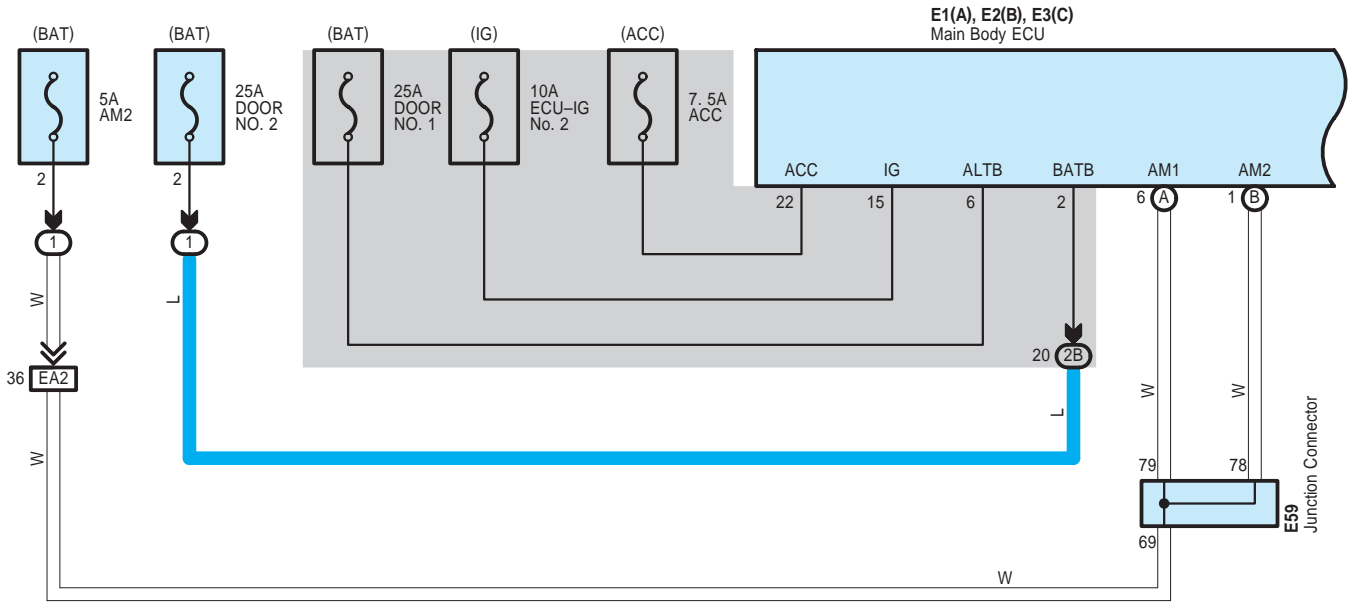

E1(A), E2(B), E3(C)  
Main Body ECU

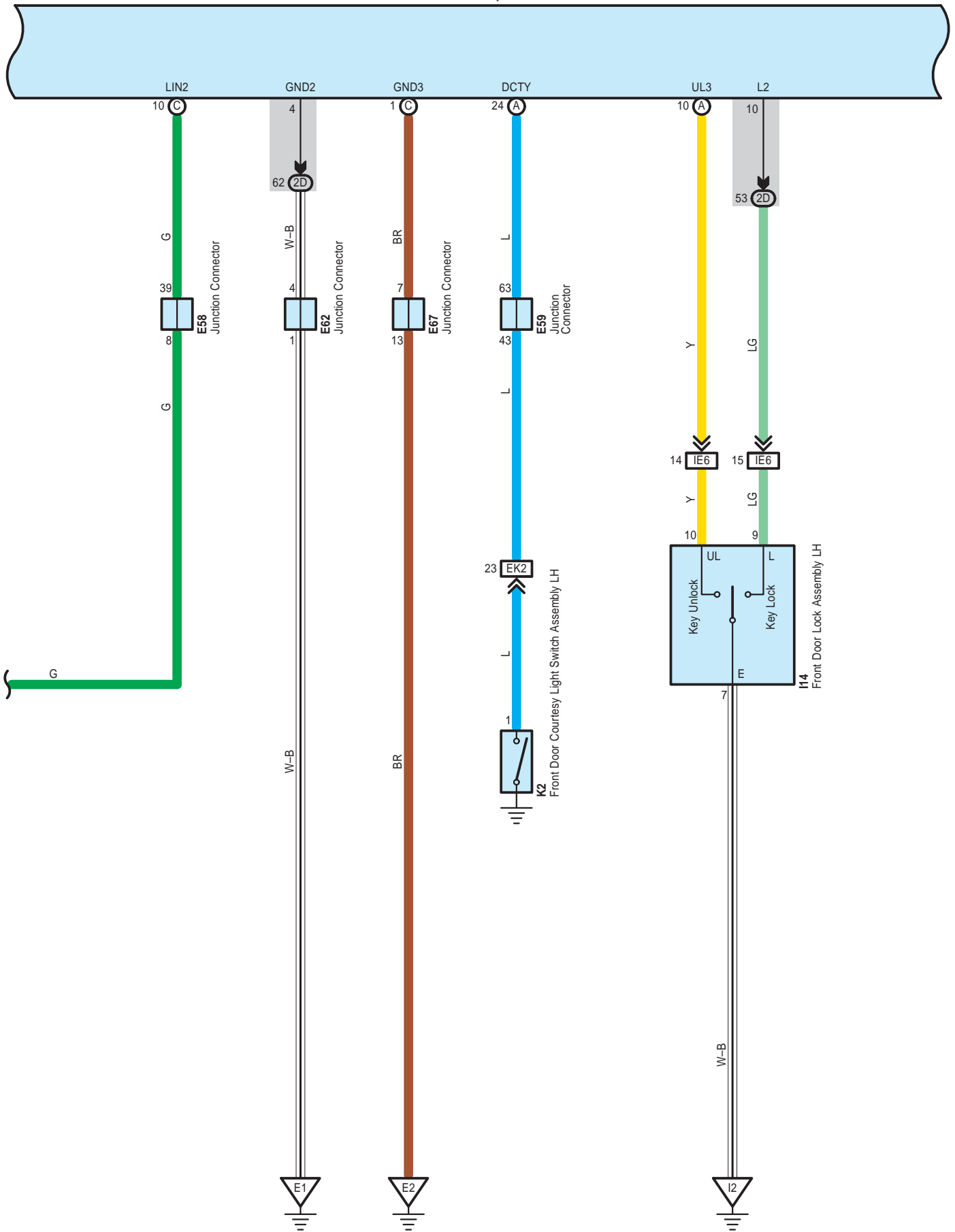



Sliding Roof

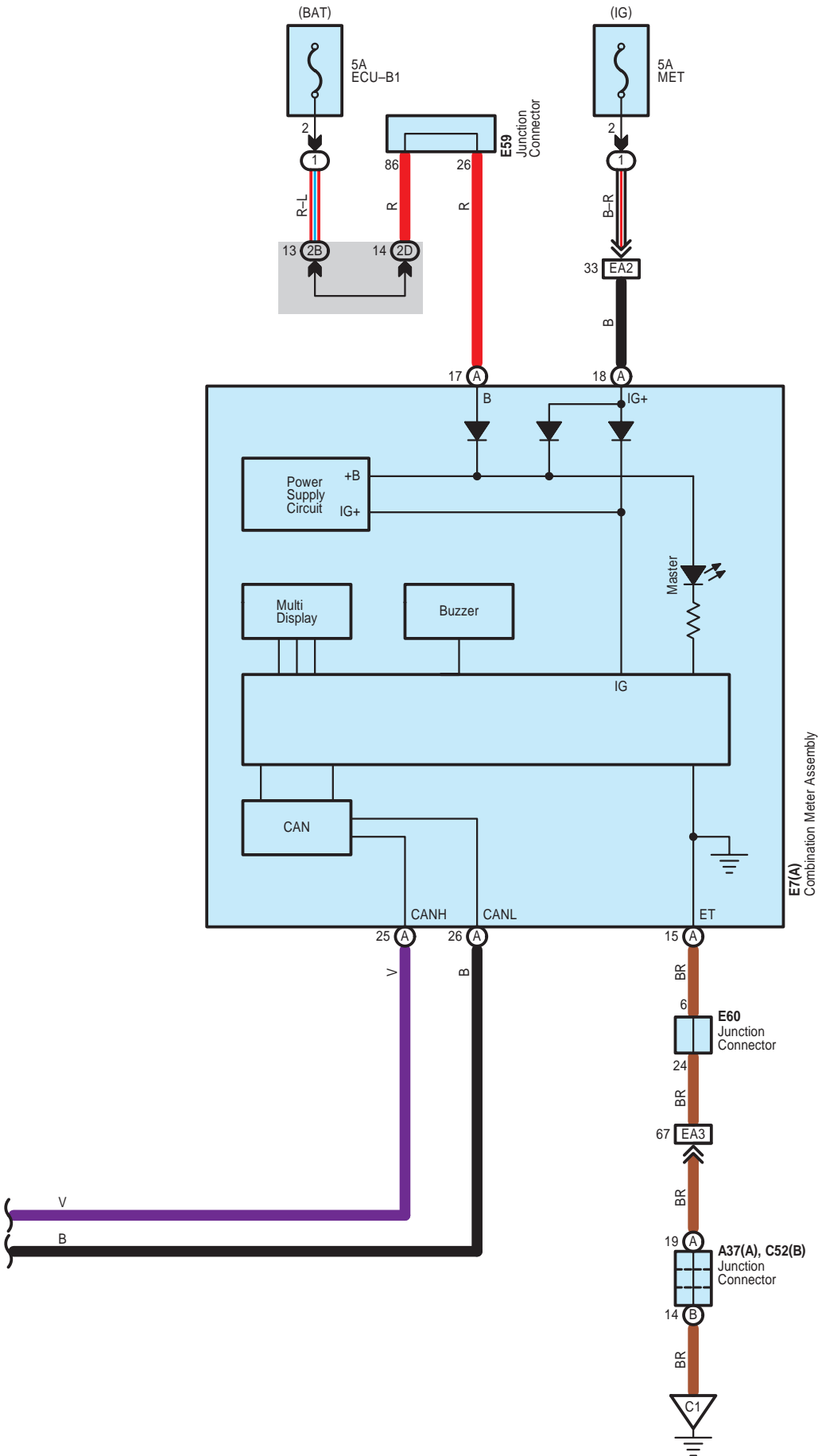

# Sliding Roof

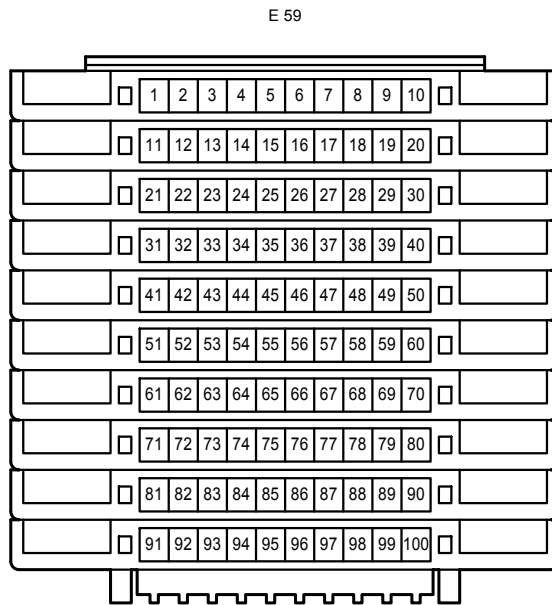
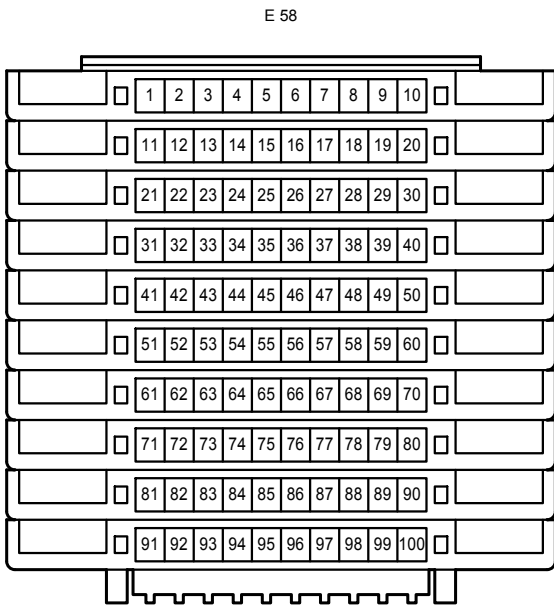
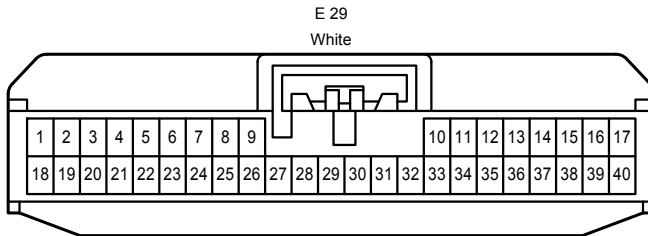
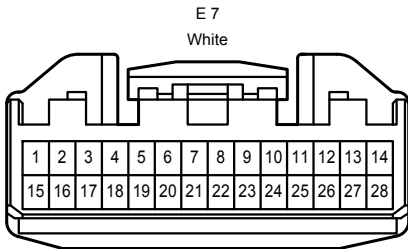
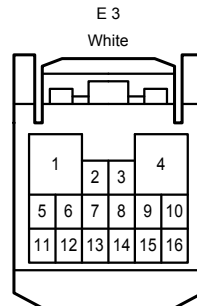
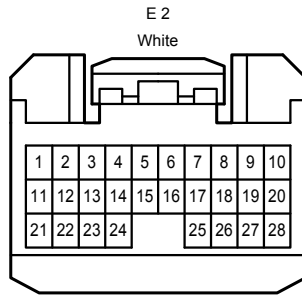
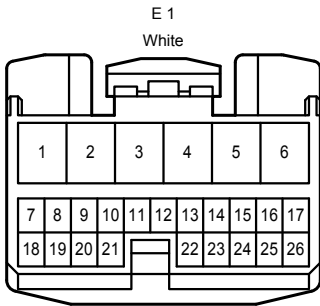
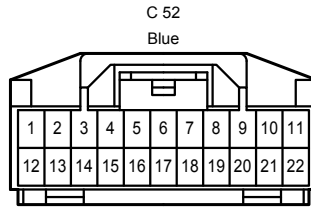
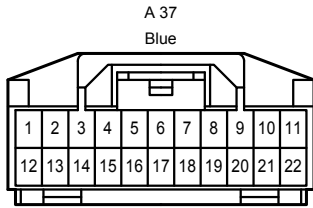
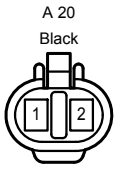

# Sliding Roof

E 60

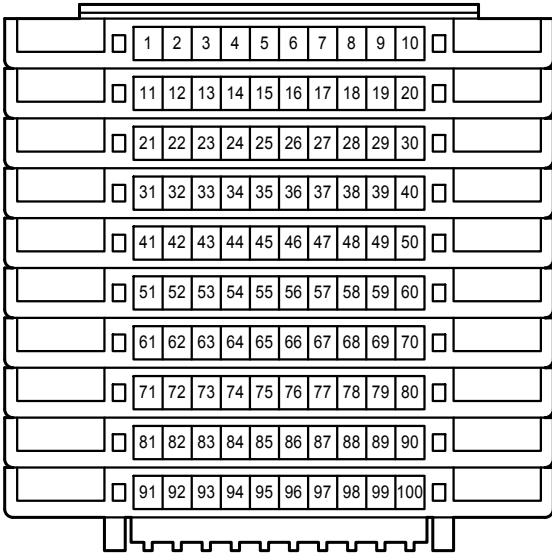

E 62  
White

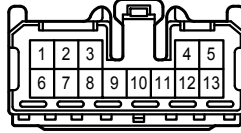

E 67  
White

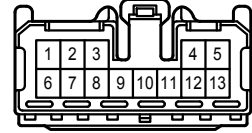

E 75  
Gray

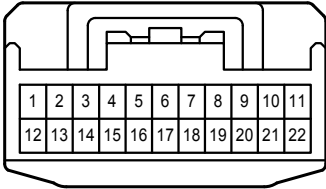

E 76  
Gray

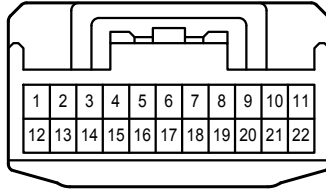

I 14  
White

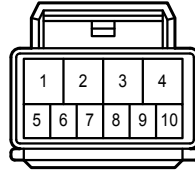

K 2  
White



L 21  
White

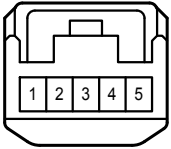

R 5  
White

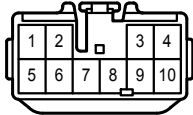

R 7  
White

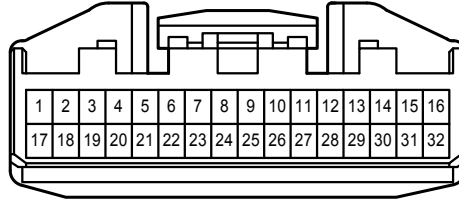

2B  
White

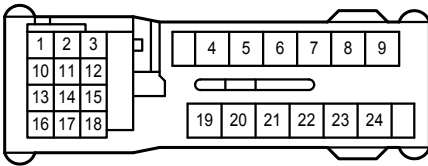

2D  
White

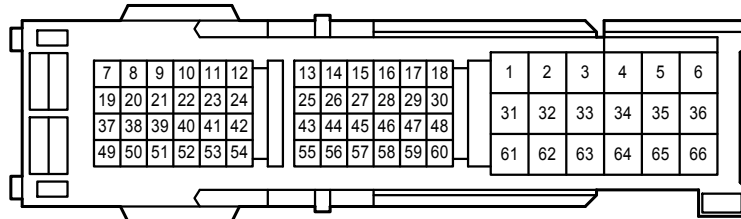

Sliding Roof

EA1  
White

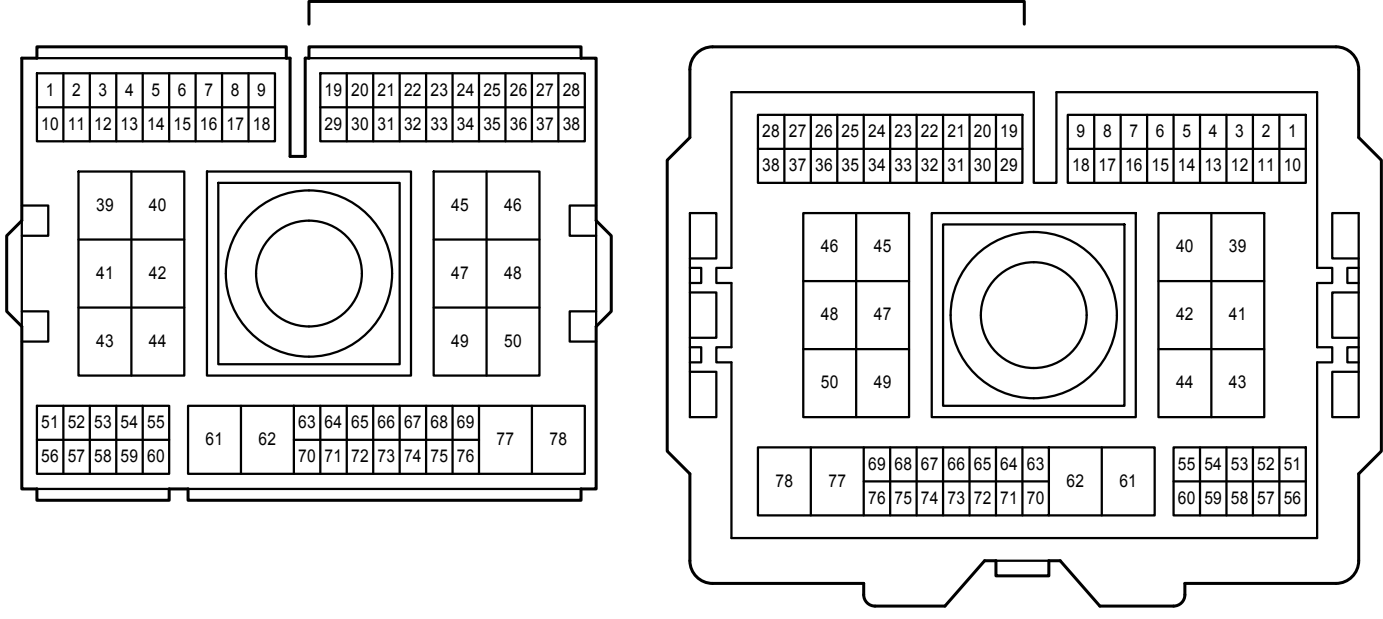

EA2

White

Gray

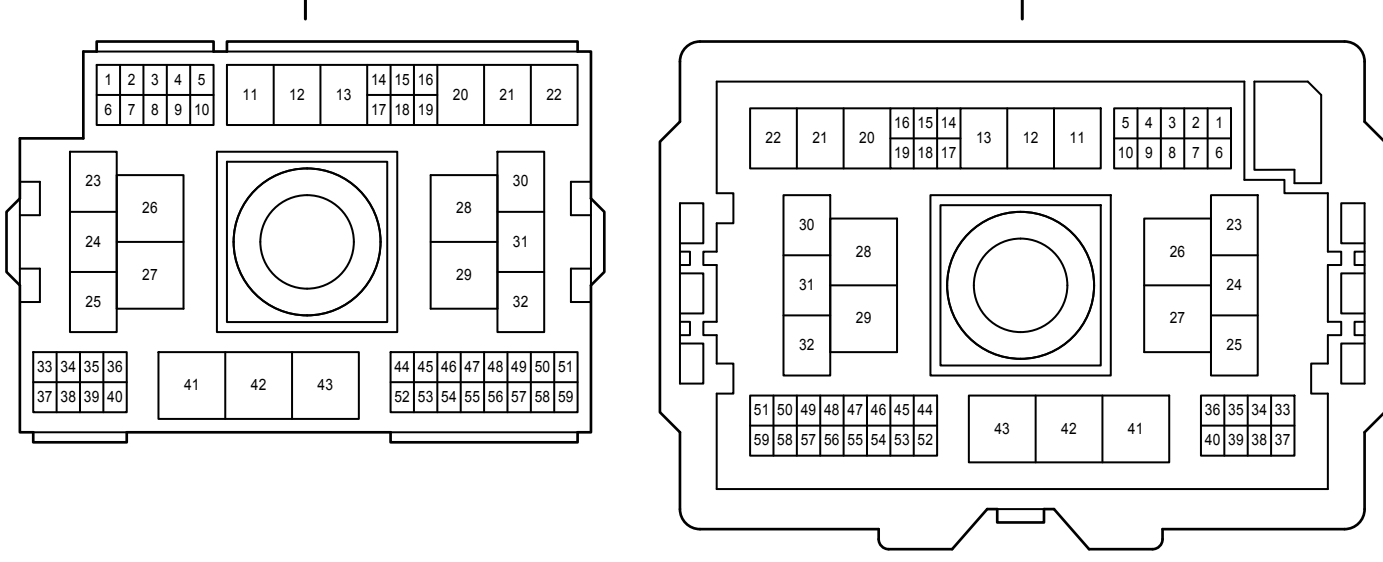



Sliding Roof

EA3  
White

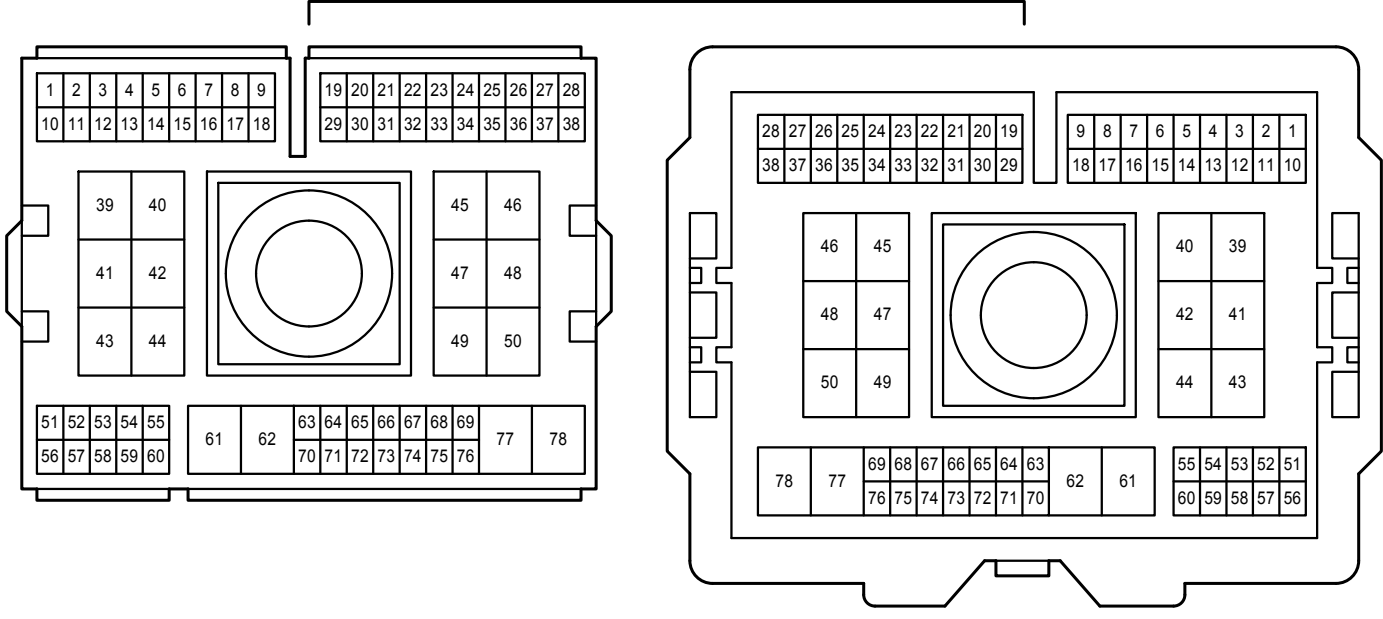

EK2  
White

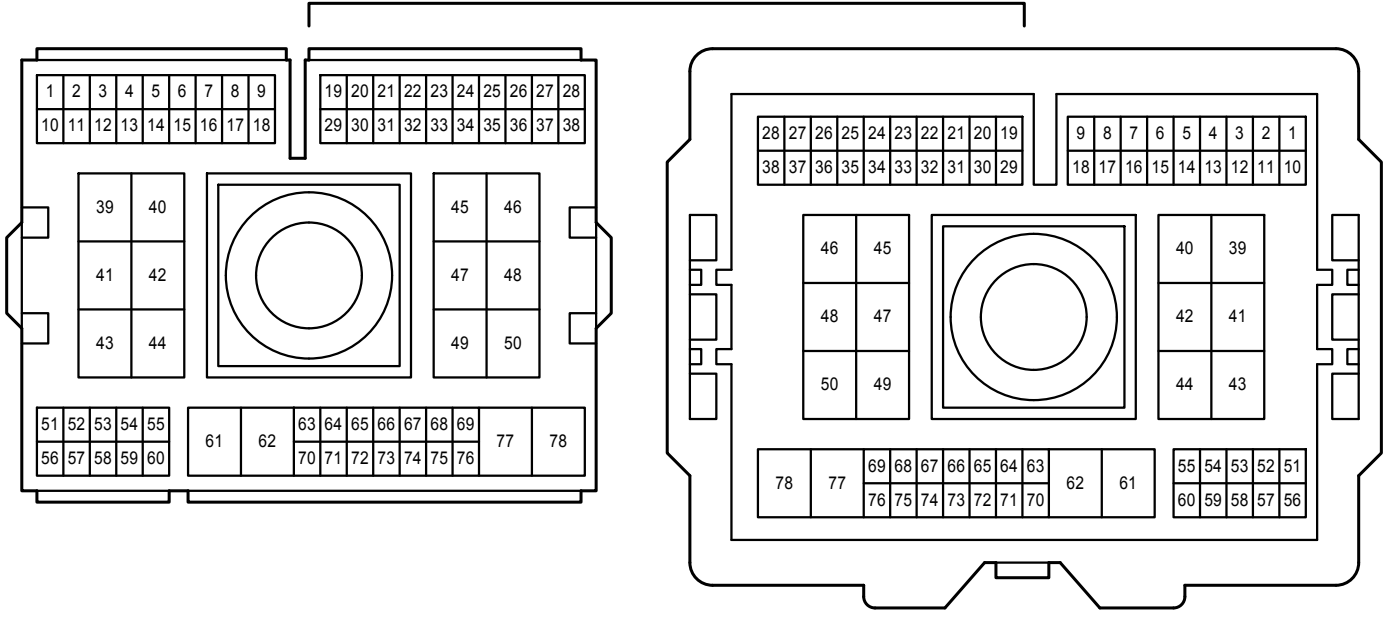

FE3  
White

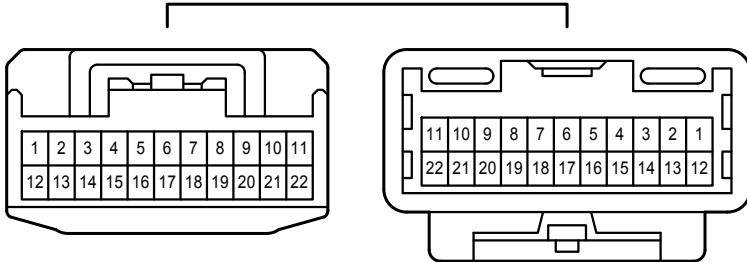

FL2  
Blue

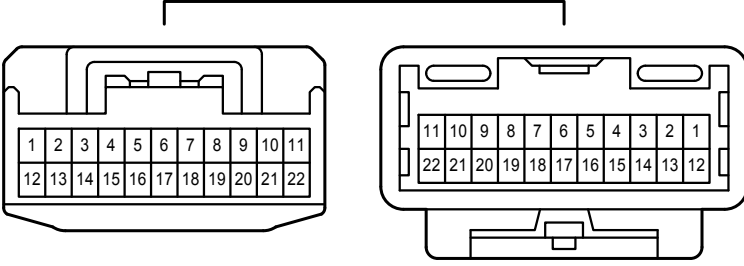

IE6  
White

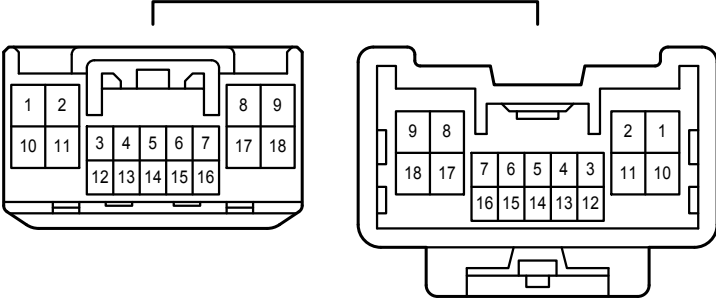

RE1  
White

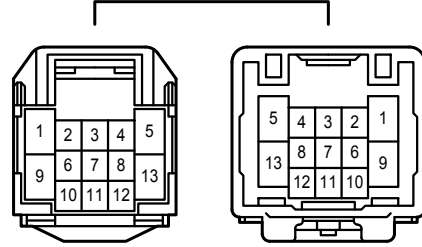

RE2  
Blue

